

Feature article

Emergency Power for Poultry Production

Power failure in a totally enclosed, controlled-environment poultry house can result in massive bird losses within minutes. Even in a house with automatic curtain drops, the shock of a sudden loss of power can cause severe losses from both mortalities and reduced performance. This is especially true if birds are near market age. Not only do flocks not tolerate drastic temperature changes well, there will simply be too many birds in the house for non-powered natural ventilation to take care of. All this means that adequately sized and reliable emergency electric power systems are essential for modern poultry houses.

Emergency Power Requirements

On the farm side of the service entrance from the power company, you have some control of conditions and can minimize power problems through proper selection, installation and maintenance of equipment. On the utility side, you are at the mercy of utility company blackouts or brownouts, thunderstorms, ice storms, lightning strikes, a car hitting a pole, and any lone squirrel that gets the urge to take a bite out of transformer wiring. Deregulation of electric utilities has so far not led to more reliable power service in most areas. On the contrary, rolling blackouts and brownouts are far more likely now than ten years ago, especially in hot weather.

Modern houses depend on power, but utility power today is not as reliable

The urgent need for quick response in case of utility power failure means that the standby power generator set must be a permanently mounted engine-driven unit controlled by an automatic transfer switch which starts the engine and transfers power whenever utility power drops below acceptable limits. An alternator run off a tractor PTO or connected by a manual transfer switch simply will not meet the need.

Urgent need for quick response means standby power must be automatically operated

This newsletter outlines in non-technical terms the main factors a grower needs to know either to evaluate an existing standby power setup or to select a new one. Growers should consult qualified professionals in choosing, modifying or installing equipment. Every farm will present at least a slightly different situation, and emergency power generation for commercial poultry is definitely not a do-it-yourself undertaking. Note: Information presented here is primarily relevant to broiler production, but also has application for breeder and pullet houses. Commercial layer operations have many requirements not covered here.

Generator Sizing

Proper sizing of a standby generator is critical, and also subject to much misunderstanding. The key point is that a generator must be able to meet not only the normal operating wattage requirements of a house (or houses), but also the start-up wattage needs, which are much greater. In a poultry house, electric motors make up most of the total electric load, and electric motors when switched on will for a few seconds draw anywhere from two to twelve times as much current than they need to run continuously after starting. A typical four-house broiler farm under full tunnel ventilation with evaporative cooling may draw around 72-75 KW under normal operating conditions, but if utility power fails, the re-start power demand on the emergency generator will be twice that amount or more, depending on whether house fans are still wind-milling or have come to a stop (see Table 1 for typical running vs cold-start power draws).

Getting the right generator capacity is critical, since the consequences of generator failure are disastrous

Fortunately, steps usually can be taken to avoid having to pay for a generator sized two or more times as large as needed to satisfy the normal running power need. In practice, broiler house generator sets with nameplate capacities of about 25 KW per house often prove to be adequate. However, the consequences of generator

failure on start-up are very serious and a conservative approach to generator sizing is highly recommended. No grower wants to pay for a larger generator than is needed; but even more so, you don't want to pay for a generator set that fails on startup.

A high-quality, conservatively-rated emergency generator will usually be able to handle brief start-up loads exceeding the unit's nameplate capacity (with a slight and brief drop in generator voltage as the equipment starts). If the generator cannot pick up the load, it may simply shut down, leaving you without power. An even worse case is that the generator does not shut down but cannot provide adequate voltage. Whenever a low-voltage condition exists, the current (amperage) goes up. If the condition goes on too long and does not trip the circuit breakers it can cause overheating and damage to electric motors in the house and/or the generator itself.

Generator must be able to handle the high starting loads imposed by poultry house electric motors

There are two major factors that determine the actual generator capacity needed:

■ Typically, one generator services 2-8 houses; if the houses are brought on in stages using time-delayed automatic transfer switches, rather than all coming on line at once, the generator doesn't have to handle the entire starting load, and can be sized smaller.

■ If ventilation controllers in individual houses can switch fans on in stages instead of all at once, the start-up amperage will be further reduced, which means the generator capacity can be further reduced. Older ventilation controllers or thermostats especially may latch all equipment in the ON position if utility power fails. In this case, the generator must be able to handle all equipment starting at once. More sophisticated controllers are able to stage equipment on as needed when power is restored, either through the utility or by the standby generator.

Using time-delayed auto transfer switches and staging controllers allows use of smaller generator

The figure of 25 KW per broiler house mentioned above is based on using time-delayed transfer switches and staging ventilation controllers. (See Table 2 for example generator loading in stages.) The generator capacity needed will vary with the number of houses being served. For example, one Southeast standby power equipment company recommends a 75KW generator for two or three houses, a 105 KW generator for four houses, a 125 KW generator for five or six houses, and a 200 KW generator for an eight-house broiler complex. Breeder houses typically have higher power requirements, and are commonly sized at 30-37 KW per house. Pullet houses usually have lower power demand, at around 20 KW per house.

Particular farm power requirements vary, and must be determined with help of a qualified professional

The above are typical figures that have proven adequate in commercial operations, *but only under the conditions stipulated and assuming proper wiring, installation, etc. Growers must be aware that individual farm requirements vary and the size generator needed for a particular farm should be determined by a qualified engineer or technician.*

Generator sets used for poultry farms are usually rated for "standby" service, not for continuous use as a primary power source. These are very satisfactory for most poultry farms, especially since the operating (not start-up) loads are rarely over 75% of the nameplate "standby" capacity.

Generator Connection and Power Transfer

The wiring connections and means of switching used are very important considerations, both for generator sizing and for safe and proper operation. Figure 1 illustrates the most important factors involved, using a typical four-house broiler complex setup example, using a 100 KW generator set and two automatic transfer switches. Important features include:

A disconnect switch and breaker on the incoming power line is needed for system maintenance

1. A fused or main breaker disconnect switch on the incoming power line, ahead of all transfer switches. This is needed to be able to work on or adjust the transfer switch without having to get the power company to shut down power to the farm. The fuse or breaker protects the transfer switch and associated wiring in case a short circuit occurs, and is a fire protection feature.
2. Transfer switches must sense loss of utility power and automatically send a signal to start the generator and then switch the farm to generator power after a short delay to allow the generator set to start and get up to

(Continued on back page)

Calculating generator size needed: Tables below present highly simplified illustrations of generator loading, for a hot summer day under full tunnel ventilation with evaporative cooling. Table values are for example only, to illustrate the principles involved. Actual running and starting wattages for particular farms will vary. Lightly-loaded motors such as fans may draw two to four times as much current to start, and motors that have to start under considerable load, such as feeder motors, may draw ten or twelve times more current on start-up. If motors are still turning when power is re-applied, the re-start power draw will be lower than for a cold start. Same-horsepower electric motors from different manufacturers, or even from the same manufacturer, may have very different starting and running amperages, depending on the purpose and design of the motor. Size of wiring and length of runs of wire will also affect wattage requirements.

Table 1. Example total starting vs continuous maximum wattage requirements for a four-house broiler farm

Equipment (per house)	Running Watts	Cold-Start Watts
10, 1-hp fans	10,000	30,000
6, 3/4-hp feeder motors	2,010	20,100
2, 1-hp water pumps	2,000	6,000
50, 75-watt lights	3,750	3,750
Total demand per house	<u>17,760</u>	<u>59,850</u>
Four houses:	71,040	239,400
Water pump:	<u>3,000</u>	<u>11,000</u>
Four-house totals:	74,040	250,400

Note: Houses may also be equipped with additional, smaller fans for minimum ventilation, but these will not come on at the same time as the large ventilation fans, which will draw more power and thus represent the maximum load.

Table 2. Example staged-start generator loading (based on Table 1 figures, in watts)

Two transfer switches, non-staged controllers:

Stage 1 start: $119,700 + 11,000 = 130,700$ (starting watts for first 2 houses + pump)

Stage 1 run: $35,520 + 3,000 = 38,520$ (running watts for first 2 houses + pump)

Stage 2 start: $38,520 + 119,700 = 158,220$ (stage 1 running watts + starting watts for second 2 houses)

Stage 2 run: $71,040 + 3,000 = 74,040$ (running watts for all four houses + pump)

Maximum starting load imposed on generator: 158,220 watts

When staging ventilation controllers are used, complete start-run staging figures are too complicated to display in a simple table. If only 2 tunnel fans are started at a time in the first two-house block, the initial Stage 1 starting wattage is reduced by 48,000 watts (16 fans x 3,000 watts each), so that the maximum starting wattage for the 2-house block will be 71,700 watts, and the Stage1 total starting watts will be:

Stage 1 start: $71,700 + 11,000 = 82,700$ ($119,700 - 48,000$ for fans + 11,000 for pump)

The Stage 1 final running wattage will be the same as above for the first two-house block, but since 71,700 watts will be the highest starting wattage, starting wattage for Stage 2 will be:

Stage 2 start: $38,520 + 71,700 = 110,220$ (Stage 1 running watts + starting watts for 2-house block minus 16 fans)

In this case, the maximum starting load imposed on generator: 110,220 watts

Figure 1. Simplified emergency generator connection wiring example for 4-house broiler farm

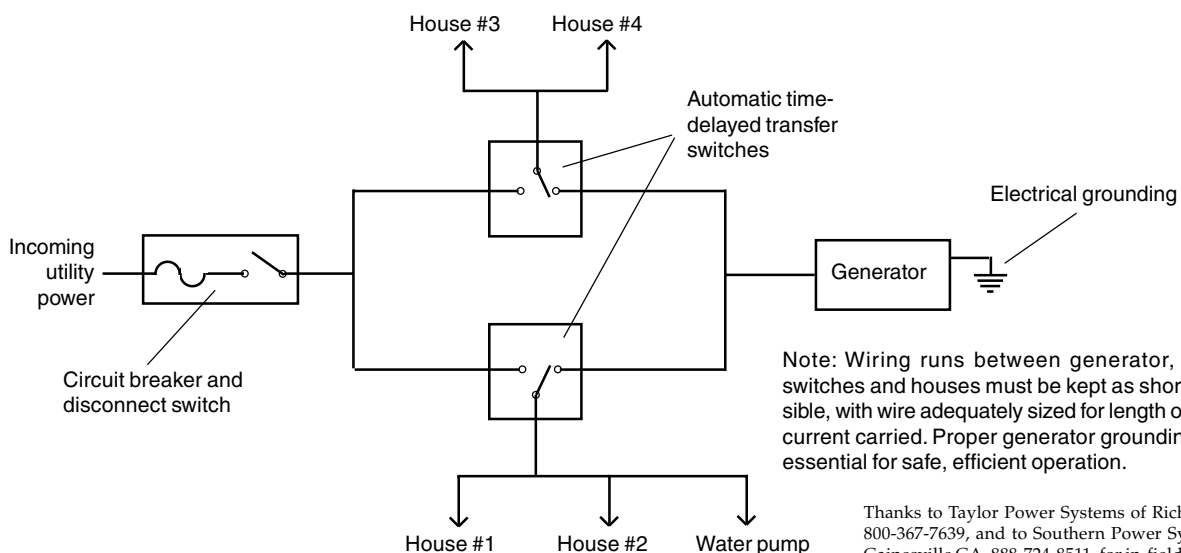

Thanks to Taylor Power Systems of Richland MS, 800-367-7639, and to Southern Power Systems, of Gainesville GA, 888-724-8511, for in-field data considered in developing this publication.

speed. For houses with automatic curtain drops, care must be taken that generator power can be brought on before the drops operate (usually about two to three minutes).

3. Transfer switches should be set to transfer houses to the standby generator whenever utility voltage drops below 90%, which would be 216 volts on a 240-volt service. The 90% set point is used because a brownout condition, with lowered utility voltage, can cause electric motors to burn out. The power or wattage requirements of the motor remain the same when the voltage drops, so that the current draw must increase. And it is the current through an electrical device that generates heat.
4. Using two transfer switches, with the second switch usually set for a 10-second delay before power is transferred, allows the generator set to be sized smaller than would otherwise be needed, since houses will be brought on standby power two at a time instead of all four at once. Power for the water well pump must be included in the first block of houses to be switched on by the standby generator.
5. Transfer to standby power should also activate an alarm warning to the operator. The warning system should include an on-site bell or siren alarm and remote electronic alarms, which can alert the manager or owner in a central office, at home, or even in a car or truck through a pager-type signal.

Auto switching to standby power also protects against brownouts, which can be as disastrous as power failure

Installation, Maintenance and Safety

To make sure standby power is properly installed and will be reliable and safe:

1. Generator set must be securely mounted in a location or housing permitting adequate ventilation for exhaust gases and to prevent overheating. "Package" units that come in pre-built housing simplify installation. For farm-built installation, consult a qualified professional.
2. Wiring runs must be kept as short as possible, and wire sizing must be adequate for both the current carried and the length of run. Wire current capacity ratings (10-gauge for 30 amps, 4-gauge for 100 amps, etc) alone do not tell you what wire size is needed. Electrical wire has small but not zero resistance to current flow, which means there will be a voltage drop across the wire run and power consumed in the wire. Wire runs that are too long for the current carried can cause excessive load on the generator and cause damage to equipment such as fan motors.
3. Whatever type of generator set used (gas, diesel or propane powered), the generator set should be run at least once a week for at least 30 minutes under full load. This is the only way to assure that both the transfer switching and generator will work properly when needed.

The Bottom Line

A good generator set with adequate controls for a modern four-house broiler farm may run \$20,000 to \$25,000. This is a small fraction of the total farm investment, and should be regarded as vital insurance, just part of the cost of doing business. It is too big a gamble to grow birds in Class A tunnel houses without standby power. If you do it, expect that you will soon (or sooner) get hit with catastrophic losses.

THANKS TO OUR CORPORATE SPONSORS

Diamond Level

Poultry Litter Treatment-PLT 800-379-2243

Platinum Level

Aerotech, Inc. 800-227-2376

Big Dutchman 616-392-5981

Hired Hand, Inc. 800-642-0123

Munters Corp. 800-446-6868

Pro-Tech, Inc. www.pro-techinc.com

Gold Level

Beacons Systems 417-345-2226

Silver Level

Chore-Time 219-658-4101

Dandy 800-222-4166

Ellison and Ellison 770-427-8929

GSI/Cumberland 217-226-4401

Monitor Co. 800-537-3201

PACTIV-Glacier Corp 800-492-2662

Val Industries 717-392-3978

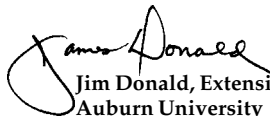

The Alabama Poultry Engineering and Economics Newsletter provides up-to-date information on topics of interest to poultry production personnel, focusing on most effective and efficient uses of modern technology and equipment, with a special emphasis on economic implications. The Newsletter is published six times a year, or as needed to address emerging or special issues. Contact: Jim Donald, Extension Biosystems Engineering, 228 Corley Bldg., Auburn University, AL 36849-5626, (334) 844-4181, fax (334)-844-3548, jdonald@acesag.auburn.edu. Published by:

Jim Donald, Extension Engineer
Auburn University

Mike Eckman, Extension Poultry Scientist
Auburn University

Gene Simpson, Extension Economist
Auburn University

Issued in furtherance of Cooperative Extension work in agriculture and home economics, Acts of May 8 and June 30, 1914, and other related acts, in cooperation with the U.S. Department of Agriculture. The Alabama Cooperative Extension System (Alabama A&M University and Auburn University) offers educational programs, materials, and equal opportunity employment to all people without regard to race, color, national origin, religion, sex, age, veteran status, or disability.

Check out – Auburn University on the Web at <http://www.poultryhouse.com>